

# Announcements

## ■ Assignment 3

- **Programming** is now **out**
  - **Due** on Nov 14<sup>th</sup> (**next Friday**)
- **Theory** (short) will be given out on **Nov 12<sup>th</sup>**
  - **Due** on **Nov 19<sup>th</sup>**

## ■ Assignment 3 Hints

- **Read the starter code carefully**
  - Only fill in the fragments of code that are needed (i.e. do not write your own classes/structures)
- Make sure you **conceptually understand** what you need to do first
- Ray tracing takes a while to render, so debugging can be slow (i.e. start right away)

---

# Radiometry: Continuation

---

**Computer Graphics, CSCD18**

Fall 2008

Instructor: Leonid Sigal



# Recall from last class...

- Light is manifested as photons
  - Number of photons at a point is zero
  - Hence, we going to talk about flux density (*i.e.* number of photons per unit area)
- **Irradiance** – amount of the light falling on the surface patch (measured in Watts/meters<sup>2</sup> )
- **Radiance** – amount of light leaving the point per area (measured in Watts/(sr \* meters<sup>2</sup>))

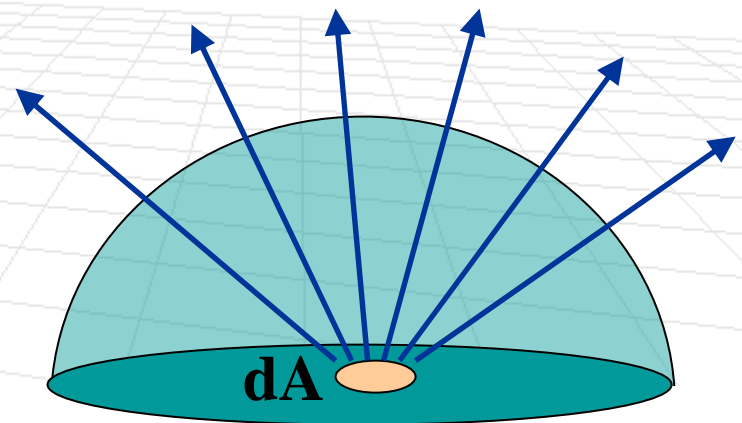
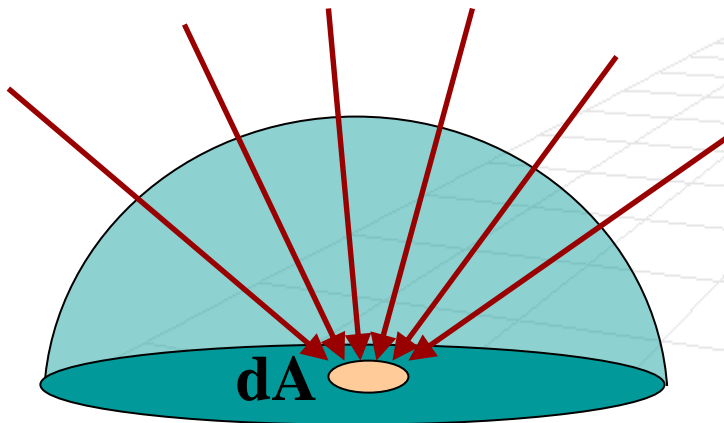

# Bidirectional Reflectance Distribution Function (BRDF)

- **BRDF:** Ratio of emittant to incident light (i.e. radiance to irradiance)

$$\rho(\vec{\mathbf{d}}_e, \vec{\mathbf{d}}_i) = \frac{\mathbf{L}(\bar{\mathbf{p}}, \vec{\mathbf{d}}_e)}{\mathbf{H}(\bar{\mathbf{p}})}$$

**Intuition:** what fraction of the light entering along one direction will be emitted in the other

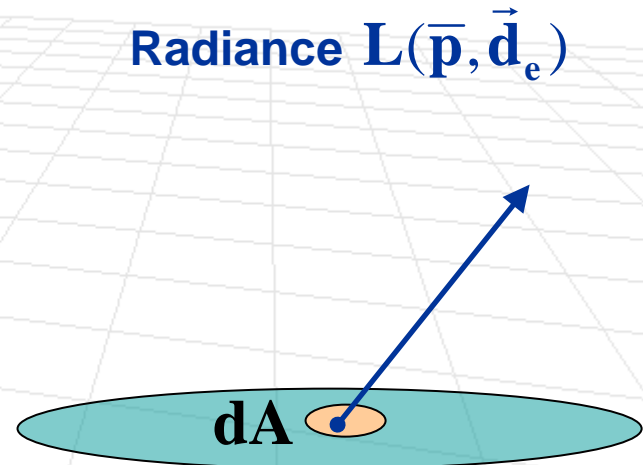
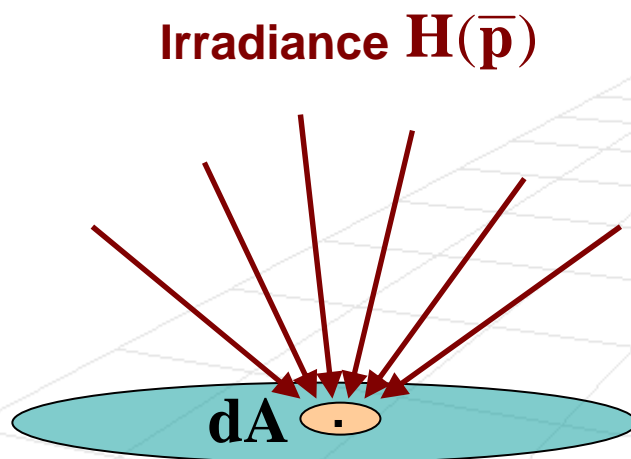

# Diffuse Reflection

- The only factor that determines appearance (radiance) of a **Lambertian** surface is irradiance (incident light)
- In other words, BRDF is constant and independent of incident and emittent direction. i.e.  $\rho(\vec{\mathbf{d}}_e, \vec{\mathbf{d}}_i) = \rho_0$
- The radiance

$$\mathbf{L}_d(\bar{\mathbf{p}}, \vec{\mathbf{d}}_e) = \rho_0 \int_{\vec{\mathbf{d}}_i \in \Omega_i} \mathbf{L}(\bar{\mathbf{p}}, -\vec{\mathbf{d}}_i) (\vec{\mathbf{n}} \cdot \vec{\mathbf{d}}_i) d\omega_i$$

$$\mathbf{L}_d(\bar{\mathbf{p}}, \vec{\mathbf{d}}_e) = \rho_0 \int_{\vec{\mathbf{d}}_i \in \Omega_i} \mathbf{L}(\bar{\mathbf{p}}, -\vec{\mathbf{d}}_i) \cos \theta_i d\omega_i$$

- Since total irradiance must equal radiant exitance (conservation of energy), we can show that  $\rho_0 = \frac{1}{\pi}$

# Small proof

$$\int_{\vec{\mathbf{d}}_i \in \Omega_i} \mathbf{L}(\bar{\mathbf{p}}, -\vec{\mathbf{d}}_i) \cos \theta_i \mathbf{d}\omega_i = \int_{\vec{\mathbf{d}}_e \in \Omega_e} \rho_0 \int_{\vec{\mathbf{d}}_i \in \Omega_i} \mathbf{L}(\bar{\mathbf{p}}, -\vec{\mathbf{d}}_i) \cos \theta_i \mathbf{d}\omega_i \cos \theta_e \mathbf{d}\omega_e$$

$$\int_{\vec{\mathbf{d}}_i \in \Omega_i} \mathbf{L}(\bar{\mathbf{p}}, -\vec{\mathbf{d}}_i) \cos \theta_i \mathbf{d}\omega_i = \pi \rho_0 \int_{\vec{\mathbf{d}}_i \in \Omega_i} \mathbf{L}(\bar{\mathbf{p}}, -\vec{\mathbf{d}}_i) \cos \theta_i \mathbf{d}\omega_i$$

$$1 = \pi \rho_0$$

$$\rho_0 = \frac{1}{\pi}$$

# Diffuse Reflection

- Despise simple BRDF, it's still hard to compute radiance because of the integral

$$\mathbf{L}_d(\bar{\mathbf{p}}, \vec{\mathbf{d}}_e) = \rho_0 \int_{\vec{\mathbf{d}}_i \in \Omega_i} \mathbf{L}(\bar{\mathbf{p}}, -\vec{\mathbf{d}}_i) (\vec{\mathbf{n}} \cdot \vec{\mathbf{d}}_i) d\omega_i$$

- Assuming point light source helps
  - Lets assume single point light source with intensity  $\mathbf{I}$
  - Then irradiance is as before  $\mathbf{H}(\bar{\mathbf{p}}) = \frac{\mathbf{I}(\vec{\mathbf{n}} \cdot \vec{\mathbf{d}}_i)}{\|\bar{\mathbf{p}} - \bar{\mathbf{e}}\|^2}$

$$\mathbf{L}_d(\bar{\mathbf{p}}, \vec{\mathbf{d}}_e) = \rho_0 \frac{\mathbf{I}(\vec{\mathbf{n}} \cdot \vec{\mathbf{d}}_i)}{\|\bar{\mathbf{p}} - \bar{\mathbf{e}}\|^2}$$

- Assuming that light is far away removes the denominator  $\mathbf{L}_d(\bar{\mathbf{p}}, \vec{\mathbf{d}}_e) = \rho_0 \mathbf{I}(\vec{\mathbf{n}} \cdot \vec{\mathbf{d}}_i)$  **Why?**

# Diffuse Reflection

- Despise simple BRDF, it's still hard to compute radiance because of the integral

$$\mathbf{L}_d(\bar{\mathbf{p}}, \vec{\mathbf{d}}_e) = \rho_0 \int_{\vec{\mathbf{d}}_i \in \Omega_i} \mathbf{L}(\bar{\mathbf{p}}, -\vec{\mathbf{d}}_i) (\vec{\mathbf{n}} \cdot \vec{\mathbf{d}}_i) d\omega_i$$

- Assuming point light source helps

- Lets assume single point light source with intensity  $\mathbf{I}$
- Then irradiance is as before  $\mathbf{H}(\bar{\mathbf{p}}) = \frac{\mathbf{I}(\vec{\mathbf{n}} \cdot \vec{\mathbf{d}}_i)}{\|\bar{\mathbf{p}} - \bar{\mathbf{e}}\|^2}$

$$\mathbf{L}_d(\bar{\mathbf{p}}, \vec{\mathbf{d}}_e) = \rho_0 \frac{\mathbf{I}(\vec{\mathbf{n}} \cdot \vec{\mathbf{d}}_i)}{\|\bar{\mathbf{p}} - \bar{\mathbf{e}}\|^2}$$

Quantity is a constant  
for a surface

- Assuming that light is far away removes the denominator

$$\mathbf{L}_d(\bar{\mathbf{p}}, \vec{\mathbf{d}}_e) = \rho_0 \mathbf{I}(\vec{\mathbf{n}} \cdot \vec{\mathbf{d}}_i) \quad \text{Why?}$$

# Remember the Phong model?

- Remember Phong lighting equation?

$$\mathbf{L}(\bar{\mathbf{p}}, \vec{\mathbf{c}}) = \mathbf{r}_d \mathbf{I}_d \max(0, \vec{\mathbf{d}}_i \cdot \vec{\mathbf{n}}) + \mathbf{r}_a \mathbf{I}_a + \mathbf{r}_s \mathbf{I}_s \max(0, \vec{\mathbf{r}} \cdot \vec{\mathbf{c}})^\alpha$$

$$\mathbf{r}_d = \rho_0 \stackrel{?}{\leq} \frac{1}{\pi}$$

- Assuming that light is far away removes the denominator

$$\mathbf{L}_d(\bar{\mathbf{p}}, \vec{\mathbf{d}}_e) = \rho_0 \mathbf{I}(\vec{\mathbf{n}} \cdot \vec{\mathbf{d}}_i)$$

# Ambient Illumination

- **Remember:** we need ambient illumination, because diffuse lighting looks artificial (parts of the object are black)
- Ambient illumination is equivalent to uniform illumination and constant BRDF (as in the diffuse case)

$$\mathbf{L}_a(\bar{\mathbf{p}}, \vec{\mathbf{d}}_e) = \rho_a \int_{\vec{\mathbf{d}}_i \in \Omega_i} \mathbf{L}(\bar{\mathbf{p}}, -\vec{\mathbf{d}}_i) (\vec{\mathbf{n}} \cdot \vec{\mathbf{d}}_i) d\omega_i$$

- It's easy to see that the integral in the above equation is simply a constant

$$\mathbf{L}_a(\bar{\mathbf{p}}, \vec{\mathbf{d}}_e) = \rho_a \mathbf{I}_a$$

# Remember the Phong model?

- Remember Phong lighting equation?

$$\mathbf{L}(\bar{\mathbf{p}}, \vec{\mathbf{c}}) = \mathbf{r}_d \mathbf{I}_d \max(0, \vec{\mathbf{d}}_i \cdot \vec{\mathbf{n}}) + \mathbf{r}_a \mathbf{I}_a + \mathbf{r}_s \mathbf{I}_s \max(0, \vec{\mathbf{r}} \cdot \vec{\mathbf{c}})^\alpha$$

$$\mathbf{r}_a = \rho_a$$

- It's easy to see that the integral in the above equation is simply a constant

$$\mathbf{L}_a(\bar{\mathbf{p}}, \vec{\mathbf{d}}_e) = \rho_a \mathbf{I}_a$$

# Specular Reflection

- For specular (mirror) surfaces each incident direction is reflected toward unique emittant direction
- The emittant direction can be derived as before in the Phong model

$$\vec{\mathbf{d}}_e = 2(\vec{\mathbf{n}} \cdot \vec{\mathbf{d}}_i)\vec{\mathbf{n}} - \vec{\mathbf{d}}_i$$

- Since all of the light is reflected into a single direction, the corresponding BRDF can be formulated as follows:

$$\rho(\vec{\mathbf{d}}_e, \vec{\mathbf{d}}_i) \propto \delta(\vec{\mathbf{d}}_e - [2(\vec{\mathbf{n}} \cdot \vec{\mathbf{d}}_i)\vec{\mathbf{n}} - \vec{\mathbf{d}}_i])$$

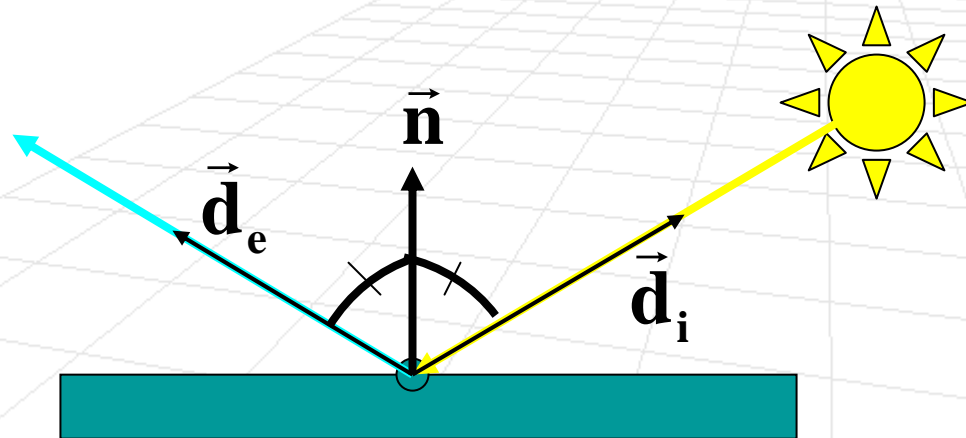

# Specular Reflection

- If we assume that light emitted is the same amount of light incident (conservation of energy), we can derive the proportionality constant

$$\rho(\vec{\mathbf{d}}_e, \vec{\mathbf{d}}_i) = \frac{1}{\vec{\mathbf{n}} \cdot \vec{\mathbf{d}}_i} \delta(\vec{\mathbf{d}}_e - [2(\vec{\mathbf{n}} \cdot \vec{\mathbf{d}}_i)\vec{\mathbf{n}} - \vec{\mathbf{d}}_i])$$

- Specular radiance can then be computed as for other components  $\mathbf{L}_s(\bar{\mathbf{p}}, \vec{\mathbf{d}}_e) = \int_{\vec{\mathbf{d}}_i \in \Omega_i} \rho(\vec{\mathbf{d}}_e, \vec{\mathbf{d}}_i) \mathbf{L}(\bar{\mathbf{p}}, -\vec{\mathbf{d}}_i) (\vec{\mathbf{n}} \cdot \vec{\mathbf{d}}_i) d\omega_i$

which simplifies in this case to:

$$\mathbf{L}_s(\bar{\mathbf{p}}, \vec{\mathbf{d}}_e) = \mathbf{L}(\bar{\mathbf{p}}, -[2(\vec{\mathbf{n}} \cdot \vec{\mathbf{d}}_e)\vec{\mathbf{n}} - \vec{\mathbf{d}}_e])$$

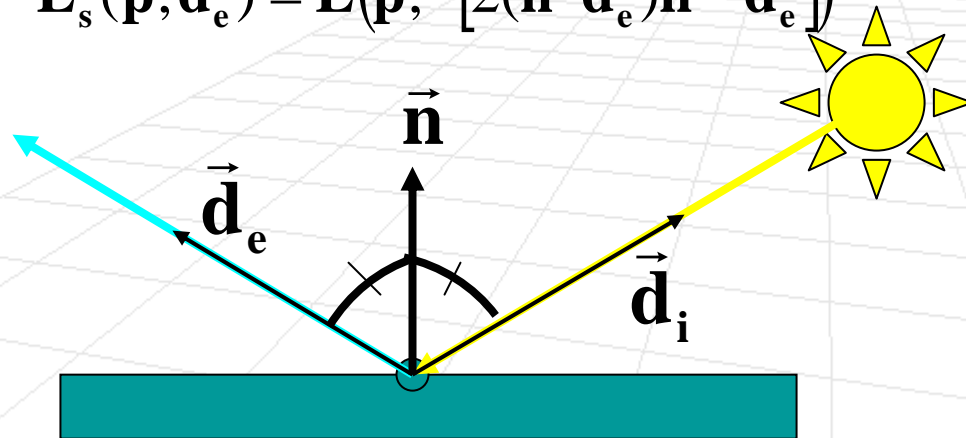

# Off-axis Secularity

- If we have more complex surfaces (not just mirrors) we will have off-axis secularities
- In that case the BRDF will not be a simple delta function and we need to go back to the full integral formulation for the radiance
- Phong model makes the point light source assumption that is far away, this leads to the approximation we already encountered

$$\mathbf{L}(\bar{\mathbf{p}}, \vec{\mathbf{c}}) = \mathbf{r}_d \mathbf{I}_d \max(0, \vec{\mathbf{d}}_i \cdot \vec{\mathbf{n}}) + \mathbf{r}_a \mathbf{I}_a + \mathbf{r}_s \mathbf{I}_s \max(0, \vec{\mathbf{r}} \cdot \vec{\mathbf{c}})^\alpha$$

# How will all of this help in Ray Tracing?

- We will consider a more accurate (and much more expensive) approximation to the radiance at the “hit point” based on the integral of the BRDF and incident irradiance
- What do we integrate over?
  - We integrate over area of a pixel

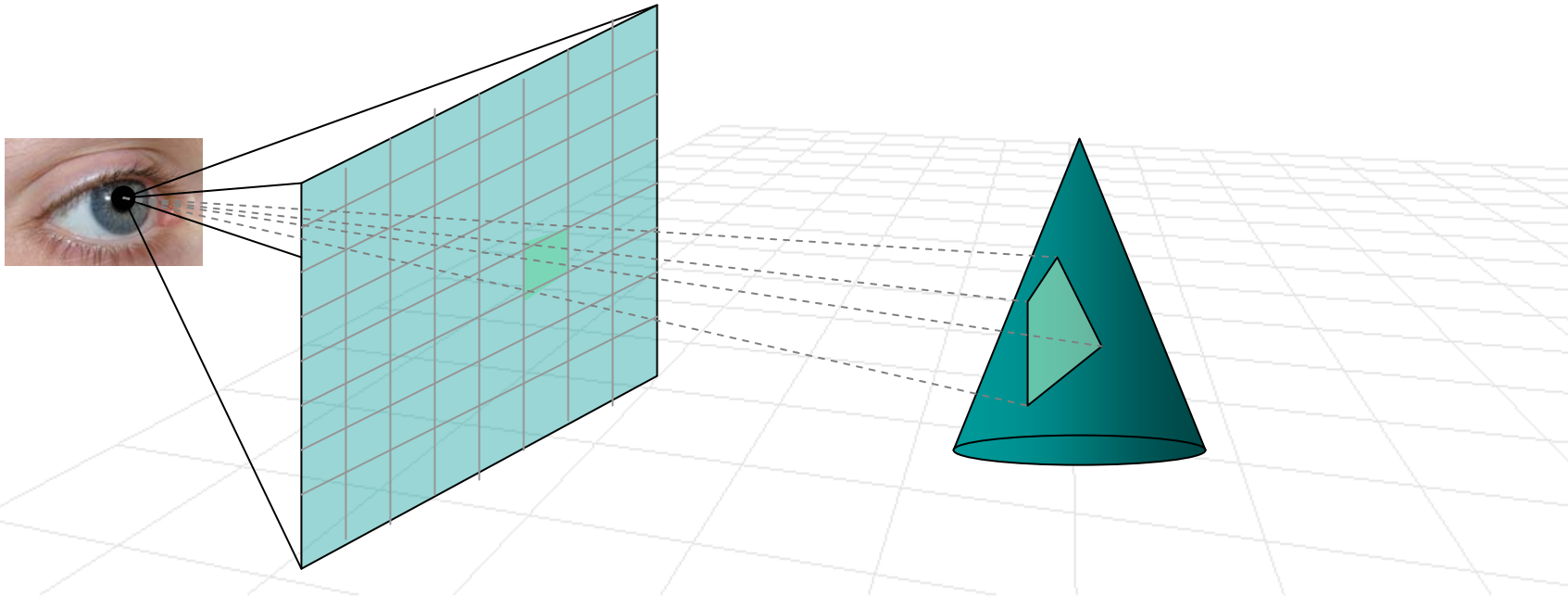

---

# Distribution Ray Tracing

---

**Computer Graphics, CSCD18**

Fall 2007

Instructor: Leonid Sigal



# Distribution Ray Tracing

- In **Whitted Ray Tracing** we computed lighting very crudely
  - Phong + specular global lighting
- In **Distributed Ray Tracing** we want to compute the lighting as accurately as possible
  - Use the formalism of Radiometry
  - **Compute irradiance at each pixel** (by integrating all the incoming light)
  - Since integrals are can not be done analytically, we will employ **numeric approximations**

# Benefits of Distribution Ray Tracing

- Better global diffuse lighting
  - Color bleeding
  - Bouncing highlights
- Extended light sources
- Anti-aliasing
- Motion blur
- Depth of field
- Subsurface scattering

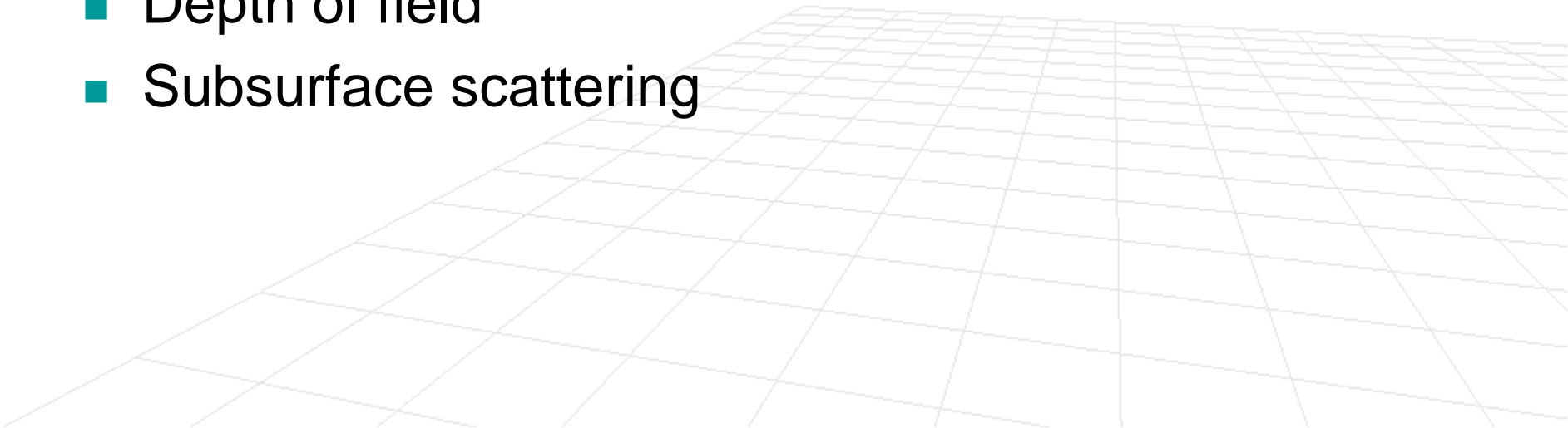

# Radiance at a Point

- Recall that radiance (shading) at a surface point is given by

$$\mathbf{L}(\bar{\mathbf{p}}, \vec{\mathbf{d}}_e) = \int_{\Omega} \rho(\vec{\mathbf{d}}_e, \vec{\mathbf{d}}_i) \mathbf{L}(\bar{\mathbf{p}}, -\vec{\mathbf{d}}_i) (\vec{\mathbf{n}} \cdot \vec{\mathbf{d}}_i) d\omega$$

- If we parameterize directions in spherical coordinates and assume small differential solid angle, we get

$$\mathbf{L}(\bar{\mathbf{p}}, \vec{\mathbf{d}}_e) = \int_{\phi \in [0, 2\pi]} \int_{\theta \in [0, 2\pi]} \rho(\vec{\mathbf{d}}_e, \vec{\mathbf{d}}_i(\phi, \theta)) \mathbf{L}(\bar{\mathbf{p}}, -\vec{\mathbf{d}}_i(\phi, \theta)) (\vec{\mathbf{n}} \cdot \vec{\mathbf{d}}_i(\phi, \theta)) \sin\theta d\theta d\phi$$

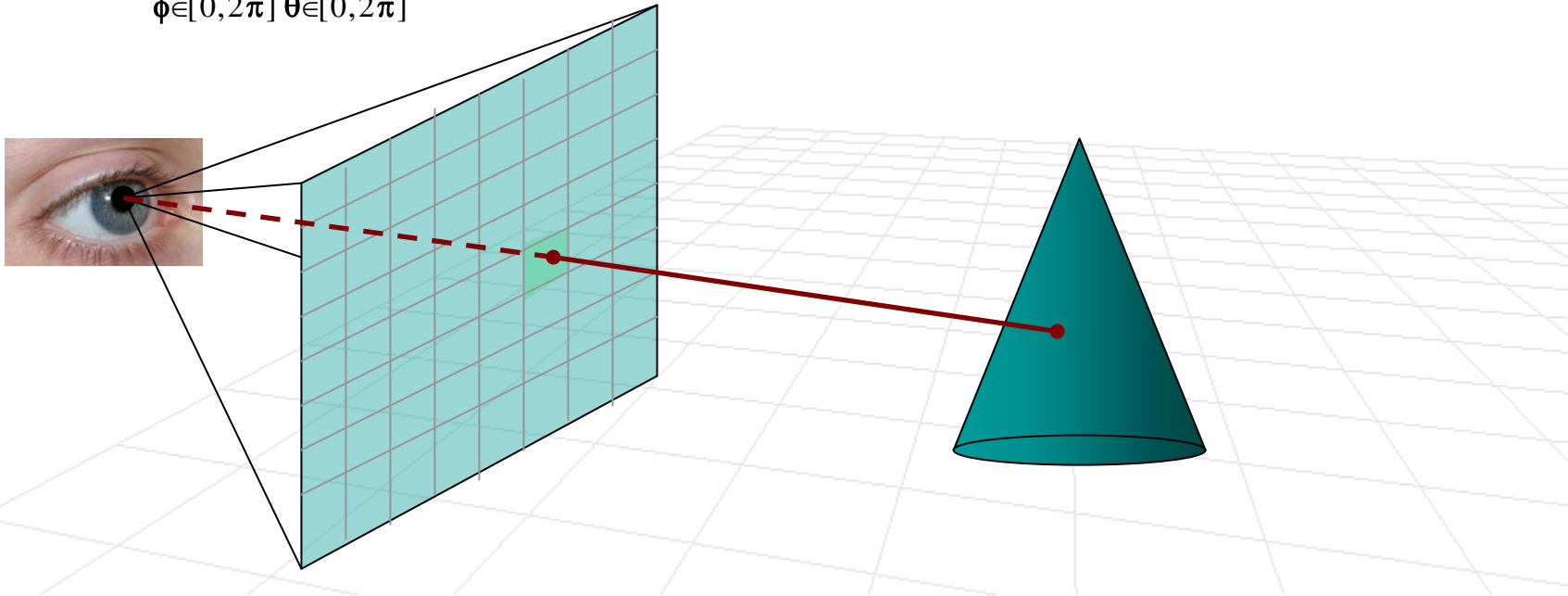

# Radiance at a Point

- Recall that radiance (shading) at a surface point is given by

$$\mathbf{L}(\bar{\mathbf{p}}, \vec{\mathbf{d}}_e) = \int_{\Omega} \rho(\vec{\mathbf{d}}_e, \vec{\mathbf{d}}_i) \mathbf{L}(\bar{\mathbf{p}}, -\vec{\mathbf{d}}_i) (\vec{\mathbf{n}} \cdot \vec{\mathbf{d}}_i) d\omega$$

- If we parameterize directions in spherical coordinates and assume small differential solid angle, we get

$$\mathbf{L}(\bar{\mathbf{p}}, \vec{\mathbf{d}}_e) = \int_{\phi \in [0, 2\pi]} \int_{\theta \in [0, 2\pi]} \rho(\vec{\mathbf{d}}_e, \vec{\mathbf{d}}_i(\phi, \theta)) \mathbf{L}(\bar{\mathbf{p}}, -\vec{\mathbf{d}}_i(\phi, \theta)) (\vec{\mathbf{n}} \cdot \vec{\mathbf{d}}_i(\phi, \theta)) \sin\theta d\theta d\phi$$

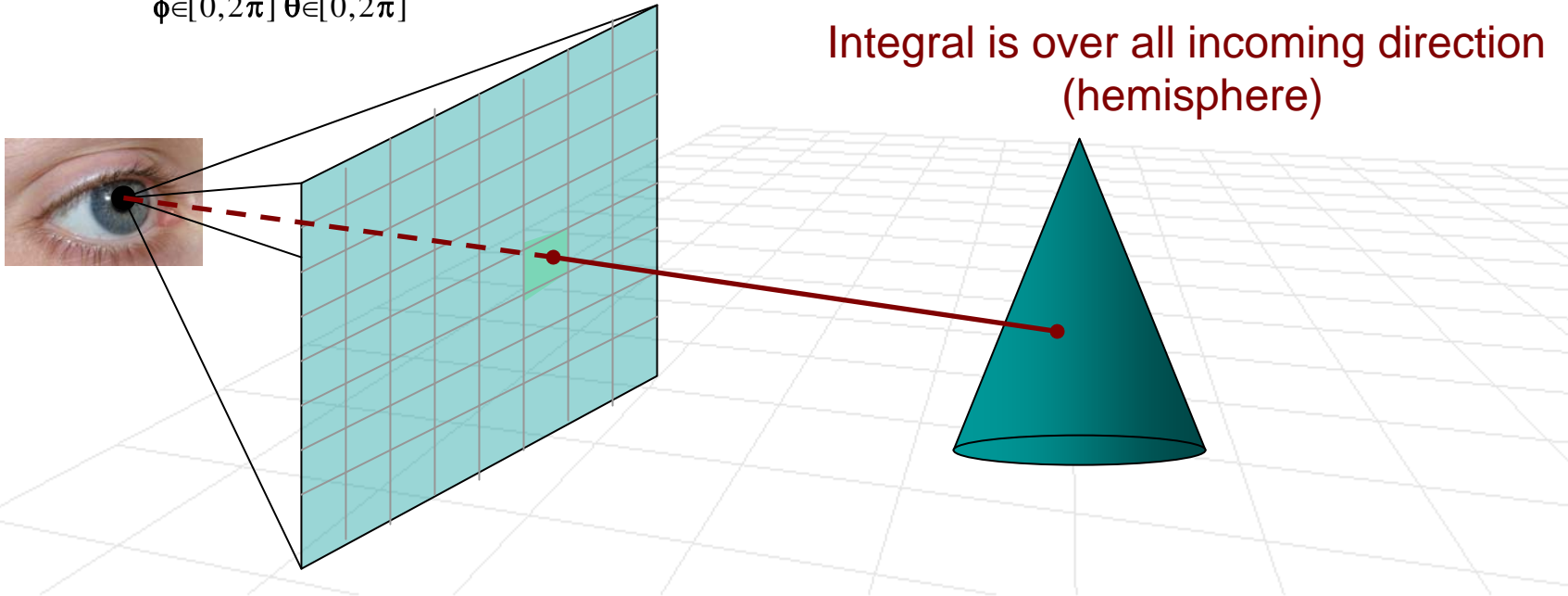

# Irradiance at a Pixel

- To compute the color of the pixel, we need to compute **total light energy** (flux) **passing through the pixel** (rectangle) (i.e. we need to compute the total irradiance at a pixel)

$$\Phi_{i,j} = \int_{\alpha_{\min} \leq \alpha \leq \alpha_{\max}} \int_{\beta_{\min} \leq \beta \leq \beta_{\max}} \mathbf{H}(\alpha, \beta) d\alpha d\beta$$

Integrals is over the extent of the pixel

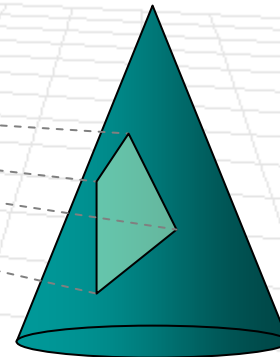
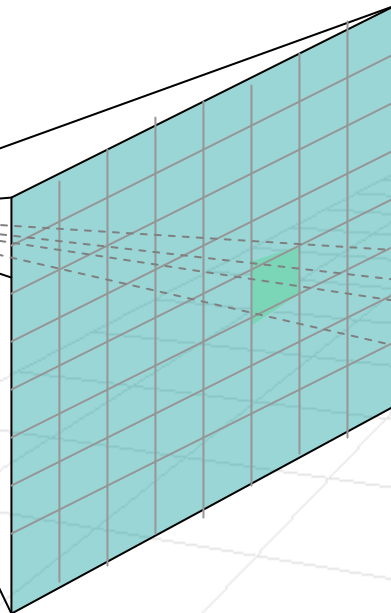
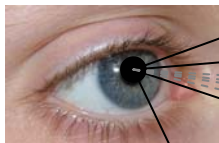

# Numerical Integration (1D Case)

- **Remember:** integral is an area under the curve
- We can approximate any integral numerically as follows

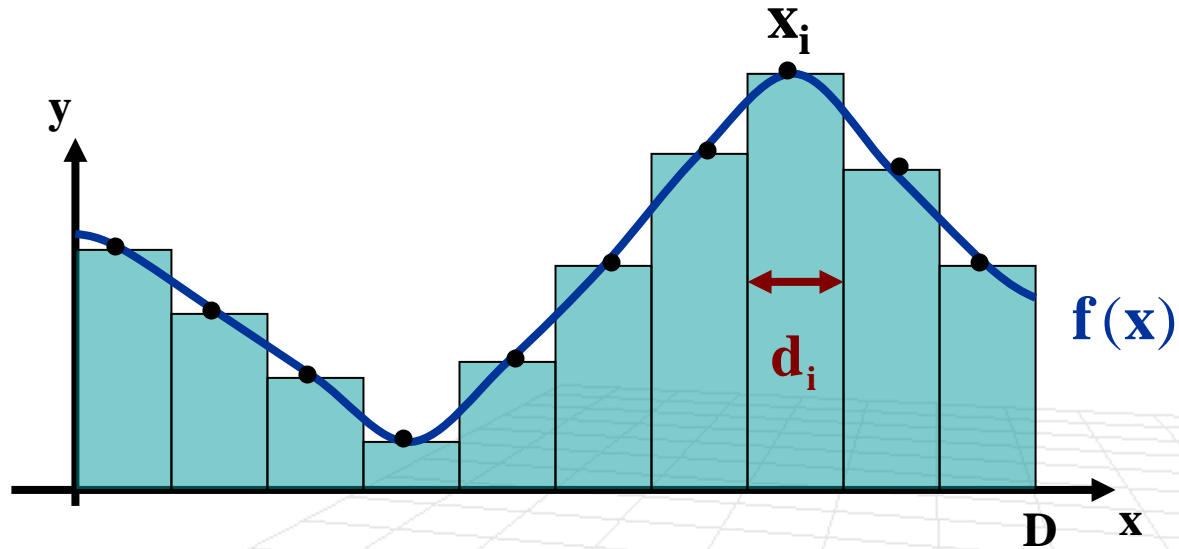

$$\sum_{i=1}^N d_i f(x_i) \xrightarrow{N \rightarrow \infty} \int_0^D f(x) dx$$

# Numerical Integration (1D Case)

- **Remember:** integral is an area under the curve
- We can approximate any integral numerically as follows

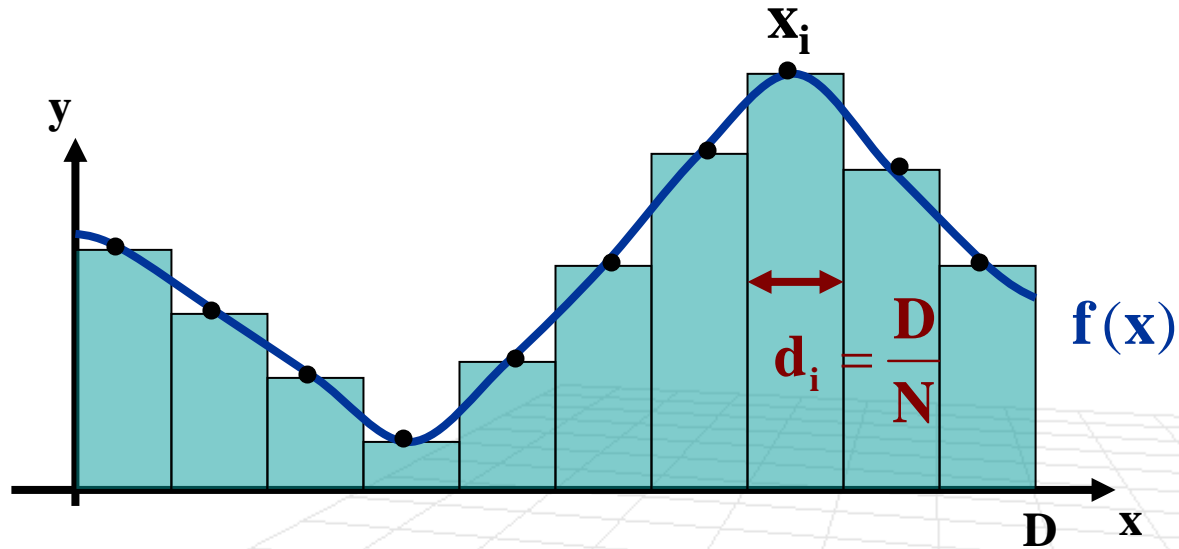

$$\int_0^D \mathbf{f}(\mathbf{x}) \, d\mathbf{x} \approx \sum_{i=1}^N \frac{D}{N} \mathbf{f}(\mathbf{x}_i)$$

# Numerical Integration (1D Case)

- **Problem:** what if we are really unlucky and our signal has the same structure as sampling?

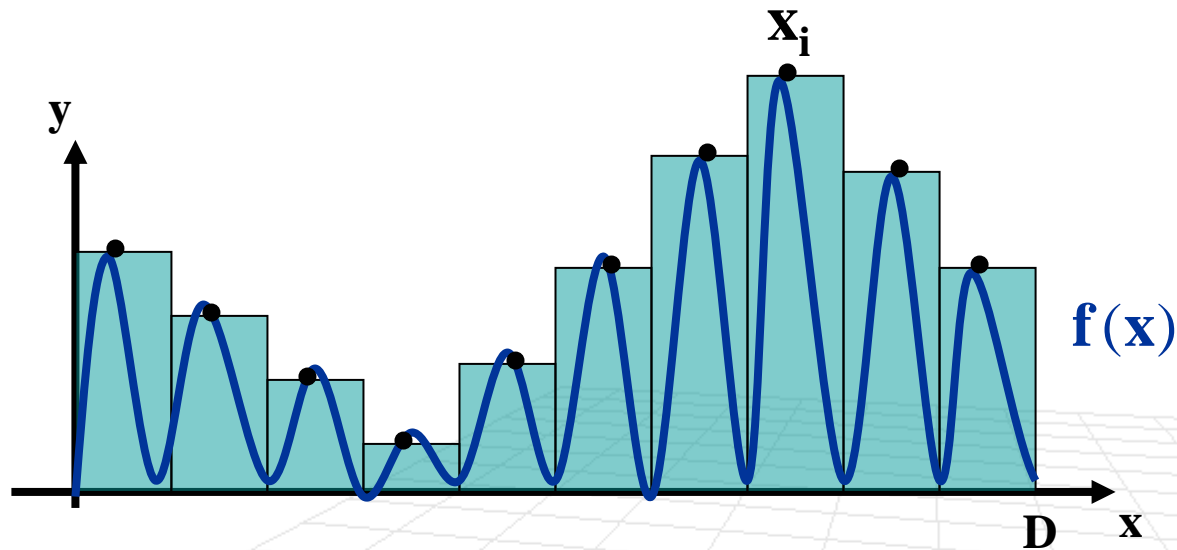

$$\int_0^D \mathbf{f}(\mathbf{x}) \, d\mathbf{x} \approx \sum_{i=1}^N \frac{D}{N} \mathbf{f}(\mathbf{x}_i)$$

# Monte Carlo Integration

- **Idea:** randomize points  $\mathbf{x}_i$  to avoid structured noise (e.g. due to periodic texture)

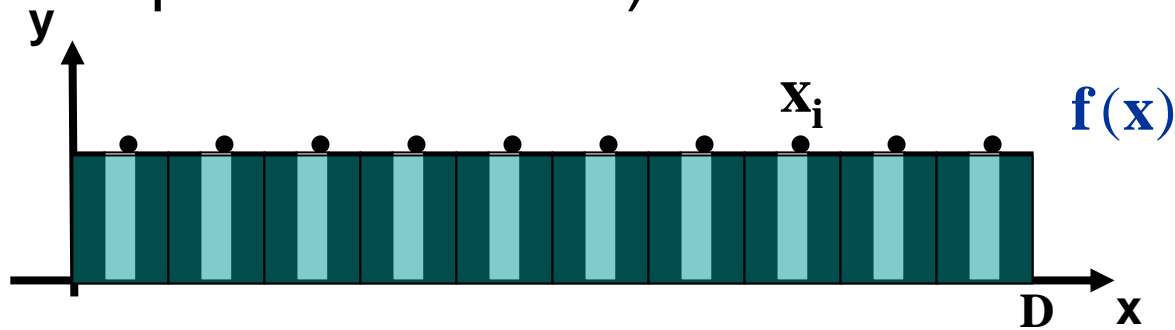

- Draw  $N$  random samples  $\mathbf{x}_i$  independently from uniform distribution  $Q(\mathbf{x})=U[0,D]$  (i.e.  $Q(\mathbf{x}) = 1/D$  is the uniform probability density function)

- Then approximation to the integral becomes

$$\frac{1}{N} \sum \mathbf{w}_i \mathbf{f}(\mathbf{x}_i) \approx \int \mathbf{f}(\mathbf{x}) \mathbf{d}\mathbf{x} \quad , \text{ for } \mathbf{w}_i = \frac{1}{Q(\mathbf{x}_i)}$$

- **We can also use other  $Q$ 's for efficiency !!!** (a.k.a. importance sampling)

# Monte Carlo Integration

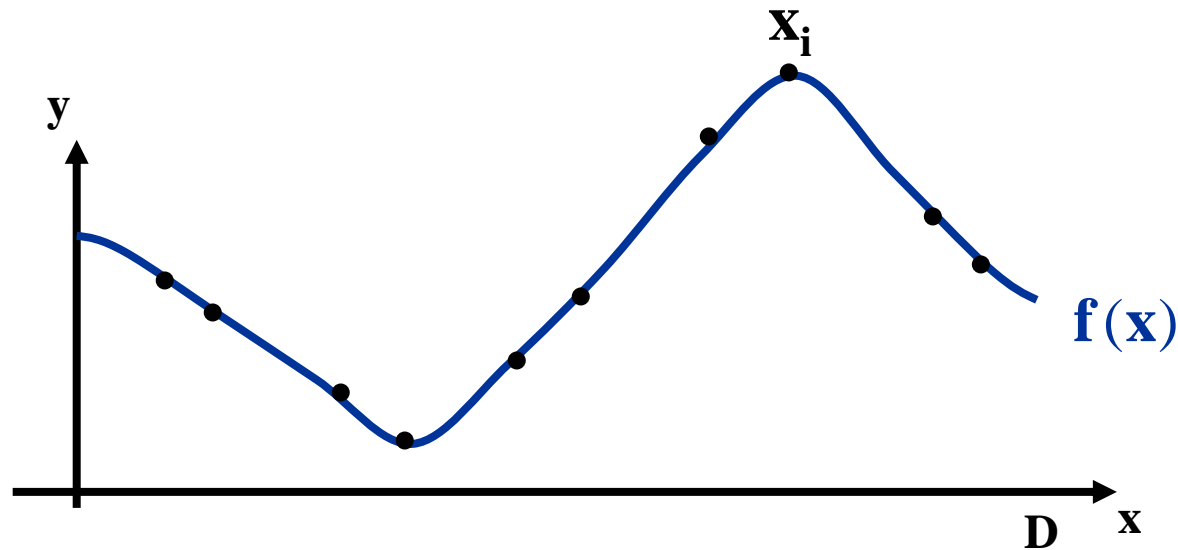

- Then approximation to the integral becomes

$$\frac{1}{N} \sum w_i f(x_i) \approx \int f(x) dx \quad , \text{ for } w_i = \frac{1}{Q(x_i)}$$

- **We can also use other Q's for efficiency !!!** (a.k.a. importance sampling)

# Stratified Sampling

- **Idea:** combination of uniform sampling plus random jitter
- Break domain into  $T$  intervals of widths  $d_t$  and  $N_t$  samples in interval  $t$

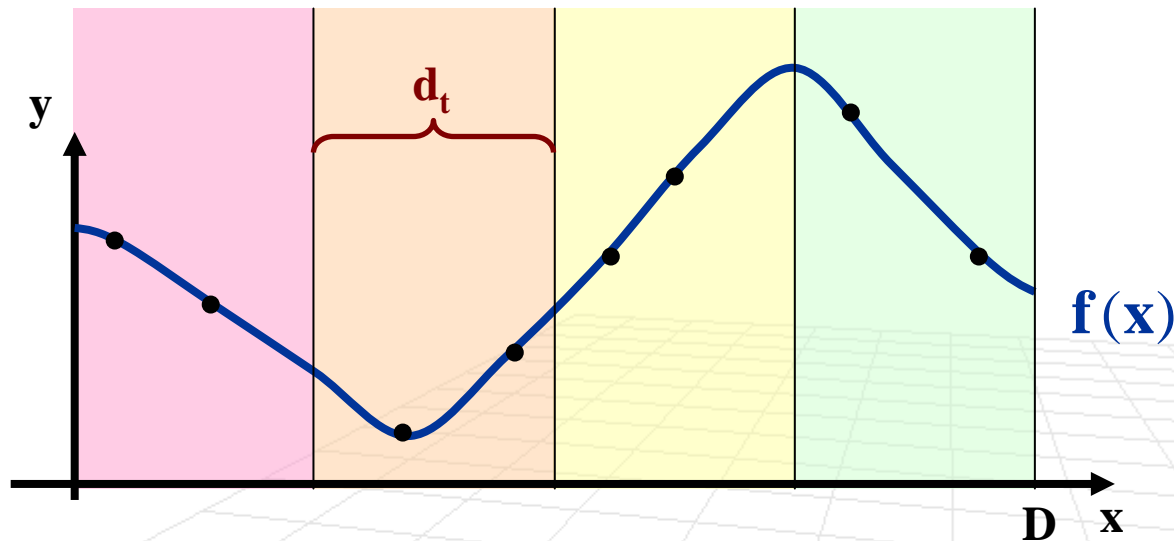

- Integral approximated using the following:

$$\sum_{t=1}^T \frac{1}{N_t} \sum_{j=1}^{N_t} d_t f(\mathbf{x}_{t,j})$$